



CITY OF CHARLESTON
 BUILDING COMMISSION
 915 QUARRRIER ST SUITE 5
 CHARLESTON WV 25301-2622

DEMOLITION PERMIT

ASBESTOS REPORT MUST BE ATTACHED TO PERMIT APPLICATION

ADDRESS OF DEMOLITION: _____

PROPERTY OWNER'S NAME: _____

PROPERTY OWNER'S ADDRESS: _____

CONTRACTOR'S NAME: _____

CONTRACTOR'S ADDRESS: _____

CITY CONTRACTOR'S LICENSE NO: _____ PHONE: _____

DEMOLITION OF: SINGLE FAMILY DWELLING

COMMERCIAL STRUCTURE

ACCESSORY STRUCTURE

EXISTING STORM AND SEWER LATERAL(S) LOCATED AND CAPPED: YES NO

TOTAL SQUARE FOOTAGE OF STRUCTURE TO BE DEMOLISHED: _____

TOTAL ESTIMATED COST* (ALL LABOR & MATERIALS) \$ _____ PERMIT FEE \$ _____

*TOTAL JOB COST EXCEEDING \$10,000 REQUIRES A COPY OF A SIGNED CONTRACT BETWEEN OWNER & CONTRACTOR.

The owner of this building and the undersigned, do hereby covenant and agree to comply with all the laws of the State of West Virginia and the ordinances of the City of Charleston pertaining to the building, and to construct the proposed renovations, repairs, and remodeling in accordance with the plans and specifications submitted herewith, and in accordance with the building codes, and certify that the information and statements given on this application, drawings and specifications are to the best of their knowledge true and correct.

According to the West Virginia Legislative Rules, Division of Health, Title 64, Series 63, Article 10.1.a. it is the responsibility of the Owner to ensure that "Each building or other man-made structure he or she owns is inspected for the presence of asbestos by a licensed asbestos inspector prior to any renovation or demolition activities". The owner of this building and undersigned, do hereby covenant and agree to comply with all the laws of the State of West Virginia and the ordinances of the City of Charleston pertaining to the building, and to construct proposed renovations, repairs, or remodeling in accordance with the plans and specifications submitted herewith, and in accordance with building codes, and certify that the information and statements given on the application, drawings, and specification are to the best of the knowledge true and correct.

 SIGNATURE OF OWNER OR REPRESENTATIVE

 DATE

DEMOLITIONS

1. All site sanitary sewer laterals and storm laterals that connect to the Sanitary Board's sanitary and combined sewers must be capped at the property line, per the Sanitary Board's requirements (see attached detail). The best time to locate the laterals is prior to total demolition, when plumbing fixtures have been removed and the existing waste piping is intact. The Sanitary Board, with advanced notice, can assist the contractor with locating the laterals outside the building with its camera equipment. Contact Mr. Mark Justice at (304)348-1084, x-239 to coordinate a camera inspection.
2. Prior to capping the existing site sanitary and storm laterals, the contractor must make advanced arrangements for the Sanitary Board's camera crew to perform a camera inspection of all laterals. Contact Mr. Mark Justice at (304)348-1084, x-239 to coordinate a camera inspection.
3. Upon completion of the Sanitary Board's camera inspection, the contractor shall cap all site laterals.
4. Prior to backfilling capped laterals, the contractor must make advanced arrangements with the Sanitary Board to inspect each cap. Contact Mr. Mark Justice at (304)348-1084, x-239 to coordinate an inspection of the capped laterals.
5. Failure of the contractor to contact the Sanitary Board for a camera inspection and cap inspection of the laterals will result in the contractor having to excavate all laterals and coordinate an inspection with the Sanitary Board.

INSTRUCTIONS FOR DEMOLITIONS PERMITS

1. You must contact the Charleston Sanitary Board (CSB) to locate and cap all sewer lines. (See instructions above.)
2. Once the sewer line is properly capped, the CSB will notify the Building Dept.
3. The Building Department will need to have a copy of an asbestos report on file.
4. If asbestos report is positive for asbestos, the asbestos will have to be removed. The Building Department will also need a letter stating the fact that the asbestos was removed and location where the asbestos was taken.
5. All contractors working on the demolition/or asbestos removal will have to be licensed with the City of Charleston, Building Department.
6. Permit fees for demolition:
Under \$5,000.00 will be \$30.00 over \$5,000.00 is based on the schedule of fees (attached).
Permit fees for asbestos removal is based on the schedule of fees (attached).

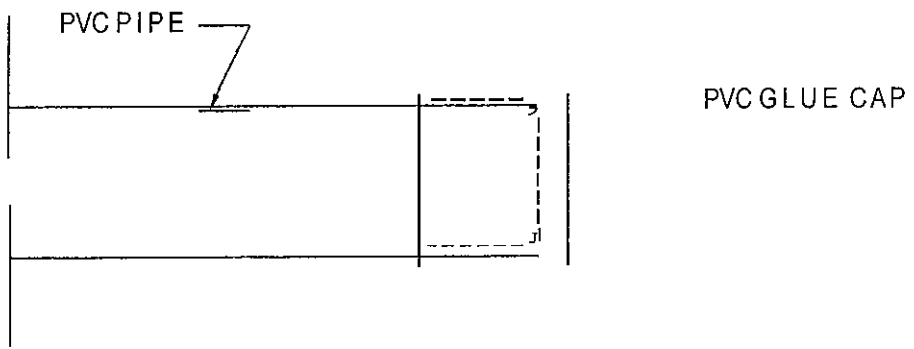

① PVC PIPE

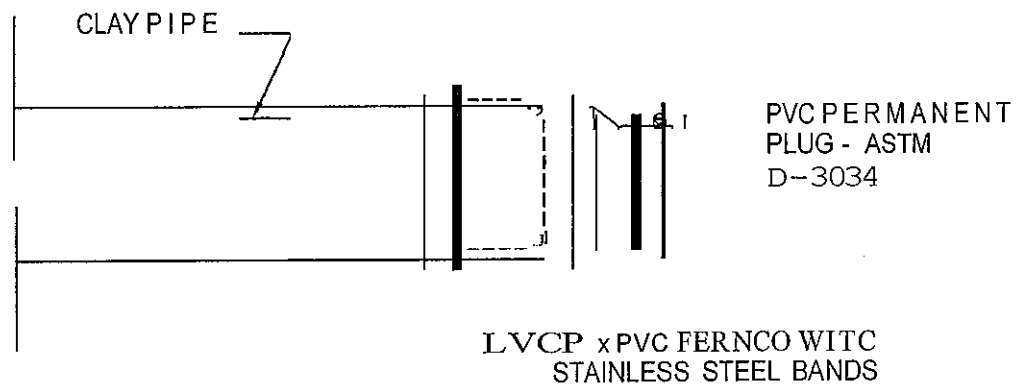

② CLAY PIPE

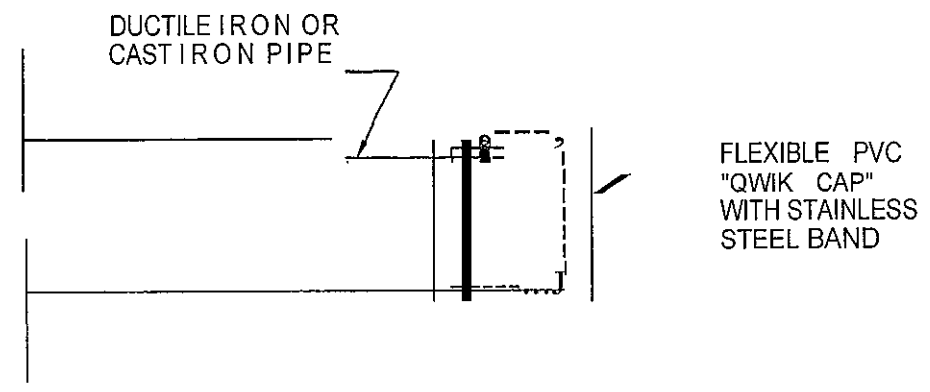

@CAST IRON OR DUCTILE IRON PIPE

(9)